



3 GHz BNC LATCHING S.P.4 T. SWITCH

OPTIONS : INDICATOR / TTL DRIVE / SUPP.DIODES

R F CHARACTERISTICS

NUMBER OF WAYS : 4
 FREQUENCY RANGE : 0 - 3 GHz
 IMPEDANCE : 50 Ohms

FREQUENCY (GHz)	0 - 3
V.S.W.R <=	1.20
INSERT. LOSS <=	0.20 dB
ISOLATION >=	80 dB
AVER. POWER (*)	240 W

ELECTRICAL CHARACTERISTICS

ACTUATOR : LATCHING
 NOMINAL CURRENT AT 25°C (±10%) : 125 mA / RESET : 500 mA (**)
 ACTUATOR VOLTAGE (Vcc) : 28V (24 to 30V) / NEGATIVE COMMON
 TERMINALS : solder pins (250°C max./30 sec.)
 INDICATOR RATING : 1 W / 30 V / 100 mA
 TTL INPUTS (E) - High level : 2.2 to 5.5V / 800µA at 5V
 - Low level : 0 to 0.8V / 20µA at 0.8V

MECHANICAL CHARACTERISTICS

CONNECTORS : BNC female per MIL C 39012
 LIFE : 2.000.000 cycles per position
 SWITCHING TIME (nominal voltage;25°C) : < 15 ms
 CONSTRUCTION : splashproof
 WEIGHT : < 460 g

ENVIRONMENTAL CHARACTERISTICS

OPERATING TEMPERATURE RANGE (°C) : -40 , +85
 STORAGE TEMPERATURE RANGE (°C) : -55 , +85

(* : average power at 25°C per RF path)
 (** RESET : supply voltage time 1sec. max./duty cycle 10%)

4112-9212 This information is given as an indication. In the continual goal to improve our products, we reserve the right to make any modifications judged necessary

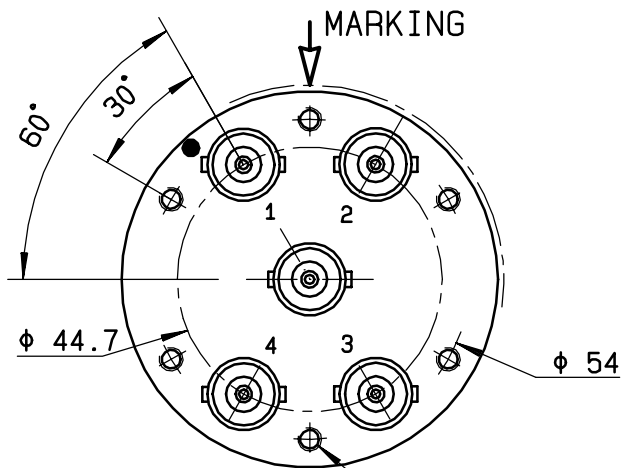

TTL input	RF continuity	Ind.
RESET = 1	All ports open	--
E1 = 1	IN ↔ 1	D.E
E2 = 1	IN ↔ 2	D.F
E3 = 1	IN ↔ 3	D.G
E4 = 1	IN ↔ 4	D.H

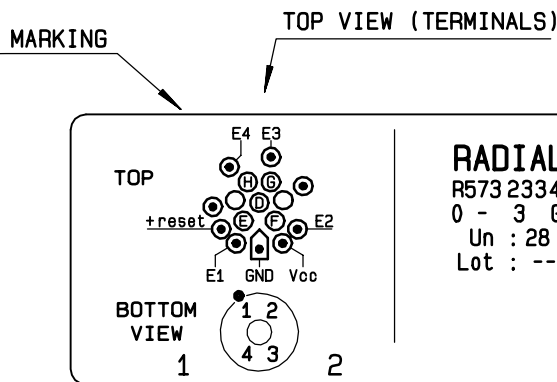
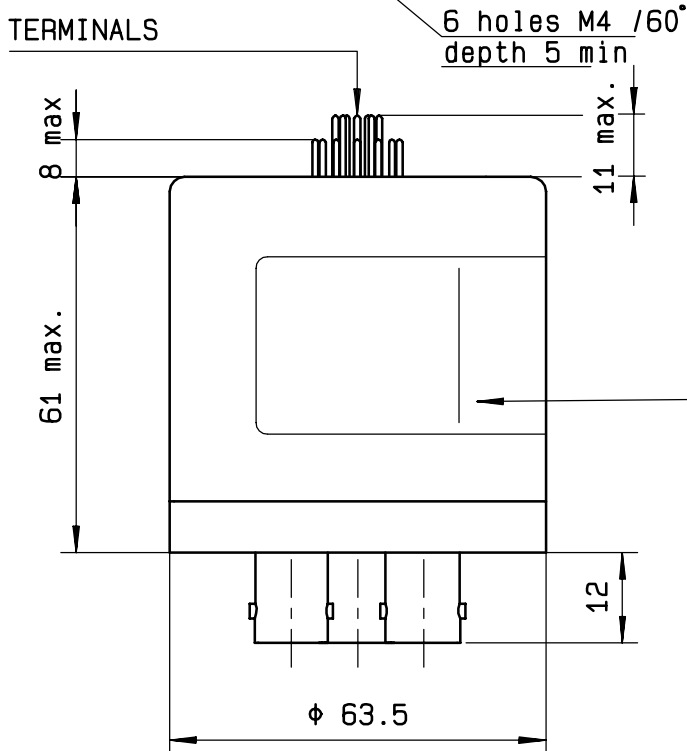

RADIAL[®]
 R573 233420
 0 - 3 GHz
 Un : 28 V
 Lot : ----

SCHEMATIC DIAGRAM

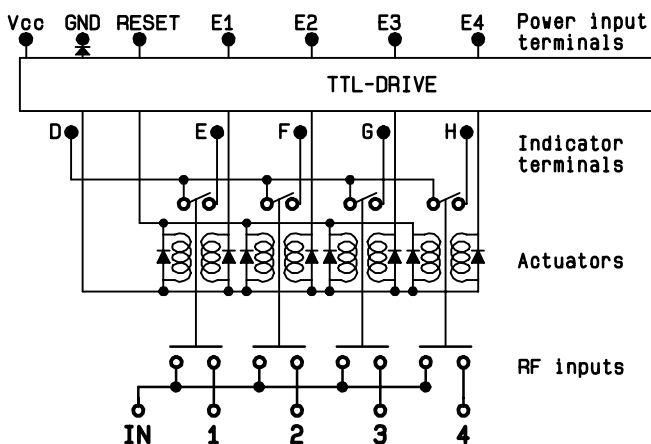

4113-9212 This information is given as an indication. In the continual goal to improve our products, we reserve the right to make any modifications judged necessary